Mathematics

Session One: Mathematics Assessment

Directions to the Student

Today you will complete Session One of this High School Mathematics Assessment. On, this part of the test, you are allowed to use tools such as calculators, rulers, protractors, and other mathematical tools.

There are several different types of questions on this test:

1. Some questions are multiple-choice questions that require you to choose the best answer.
2. Some questions require short answers. You may be asked to show your work, explain your answer, draw a diagram, or show the steps you use to solve a problem.
3. Some questions require more details (graphs, tables, written summaries) or more descriptions or explanations.

Sample questions have been included to show you the different types of questions you will find on the test and how to mark or write your answers.

There are several important things to remember:

1. Read each question carefully and think about the answer.
2. When you are supposed to write your answers, write them neatly and clearly in the box provided. Show all of your work. Do not erase any work you do not want as part of your answer. Simply cross it out.
3. When you are supposed to select the answer, make sure you fill in the circle next to the answer.
4. Use only a **No. 2 pencil**, not a mechanical pencil or pen. If you do not have a No. 2 pencil, ask for one.
5. Mark your answers directly in the space provided in your test booklet. Do not use scratch paper.
6. If you do not know the answer to a question, skip it and go on. You may return to it later.
7. If you finish the test early, you may check over your work in Mathematics Session One only. You may not go on to the next Mathematics session.
8. When you reach the word **STOP** in your booklet, stop. Do **not** go on until you are told to turn the page.

Go On ▶

Sample Questions

To help you understand how to answer the test questions, look at the sample test questions below. They are included to show you what the questions in the test are like and how to mark or write your answers in your test booklet.

Sample Multiple-Choice Question

For this type of question, you will select the answer and fill in the circle next to it.

- 1 Thomas received m dollars for his allowance. He spent $\frac{1}{3}$ of his allowance on a CD and $\frac{1}{2}$ of his allowance on movies and snacks. Which expression represents the number of dollars he had left?

A. $1 - \frac{1}{3}m - \frac{1}{2}m$

B. $m - \frac{1}{3}m - \frac{1}{2}m$

C. $1 - \frac{1}{3}m + 1\frac{1}{2}m$

D. $m - \frac{1}{3}m + 1\frac{1}{2}m$

For this sample question, the correct answer was **B**. Therefore, the circle next to **B** was filled in.

Go On ▶

Mathematics

Sample Short-Answer Question

- 2 The average (mean) weight of three members of a bobsled team is 161 lb. When the weight of the driver (the fourth member) is added, the average weight of the team becomes 165.5 lb.

How much does the driver weigh?

Show your work using words, numbers, and/or labeled diagrams.

$\frac{A+B+C}{3} = 161 \text{ lb average} \rightarrow A+B+C = 483 \text{ lb}$
$\frac{483+D}{4} = 165.5 \text{ lb.} \rightarrow 483+D = \underline{662 \text{ lb}}$
$D = 179 \text{ lb.}$
$\text{Driver's weight} = 179 \text{ lb.}$

This example shows a student response that is complete. The student has shown each step in the solution process. The final answer of 179 pounds is clearly labeled.

Go On ▶

Sample Extended-Response Question

- 3 Mrs. Andrews is supervising an independent study course. Each of the students is required to complete 20 assignments. The list below shows how many assignments each student has completed.

Student	Number of Assignments Completed
Mike Cooper	10
Manuel Flores	15
Latasha Williams	11
Sondra Rao	10
Tam Chan	14

Use the grid to create a bar graph that shows the **percentage** of assignments completed by each student. Be sure to:

- label the axes
- label the categories
- use an appropriate scale
- accurately record the data

Work space.

$10/20 = 50\%$ $15/20 = 75\%$ $11/20 = 50\%$ $14/20 = 70\%$
--

Go On ►

Mathematics

3 (continued)

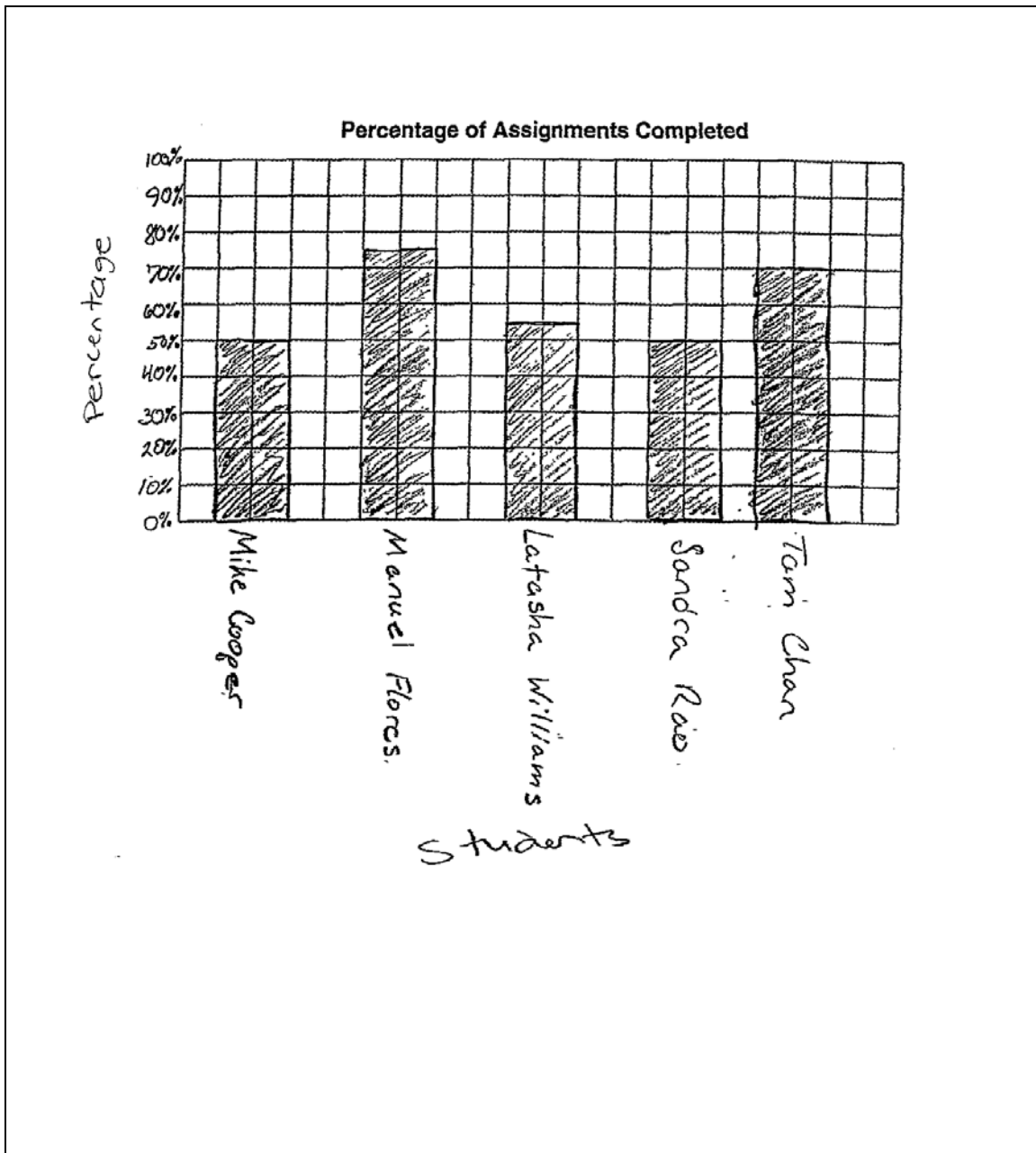

This example shows a response that completely responds to the requirements of the test question. The student figured out the percent for each student and then drew a clear and well labeled graph that accurately represents the percents. The graph shows effective mathematical communication. The axes are accurately labeled, the scale is appropriate for the data, and the names of the students are clearly labeled. The response also shows accurate representation of the data on the graph.

STOP

5

Reminder: Use a No. 2 pencil only. Do not use a mechanical pencil or pen.

- 1 Henrietta is stacking soup cans for a display in the grocery store where she works. The bottom level of the display has 100 cans arranged in a square. The next level up has 81 cans in a square. The level above that has 64 cans in a square. She continues this pattern until she has just one can at the top.

How many cans does she have altogether in this display?

- A. 246
- B. 385
- C. 450
- D. 550

- 2 A 5-foot-tall person casts an 8-foot shadow. A vertical pole that supports a basketball hoop is 12 feet high.

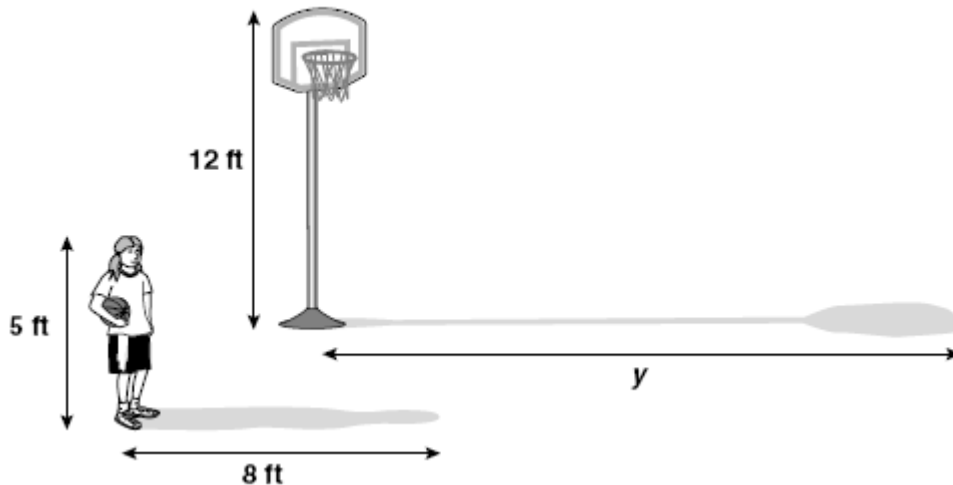

How long is the shadow of the pole?

- A. 7.5 feet
- B. 15 feet
- C. 19.2 feet
- D. 25 feet

Go On ▶

Mathematics

- 3 In the diagram, \overline{HM} is perpendicular to \overline{KF} .

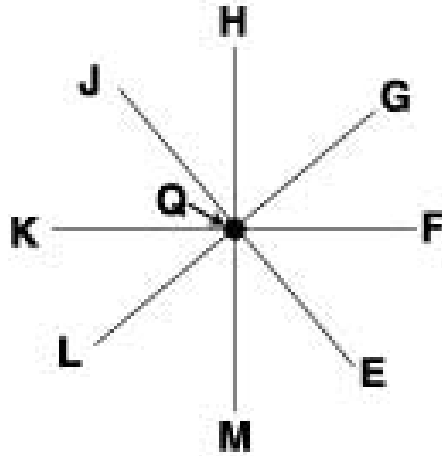

If you are at Q facing H and turn 315° clockwise, then 45° counterclockwise, what point will you be facing?

- A. H
- B. F
- C. M
- D. K

Go On ▶

Mathematics

- 5 In a certain carnival game, a player gets to spin each of the spinners once.

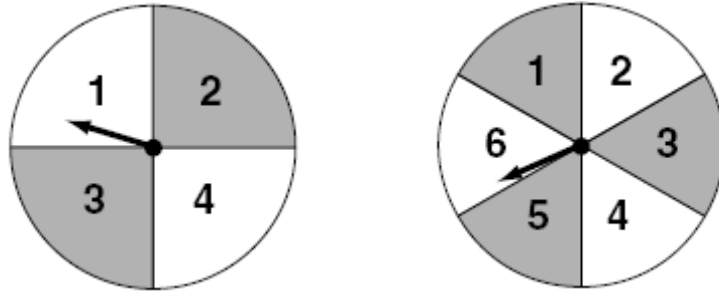

What is the probability of getting two numbers that have a sum of 7?

- A. $\frac{1}{4}$
 - B. $\frac{1}{6}$
 - C. $\frac{5}{12}$
 - D. $\frac{7}{24}$
- 6 Find the rule for number pattern in the table.

x	y
2	10
4	22
6	34
8	58

- A. $y = 4x + 2$
- B. $y = 6x - 2$
- C. $y = 7x - 4$
- D. $y = 5x + 4$

Go On ▶

- 7 On Enrique’s grid, find all the points whose x coordinate is one third of its y coordinate.

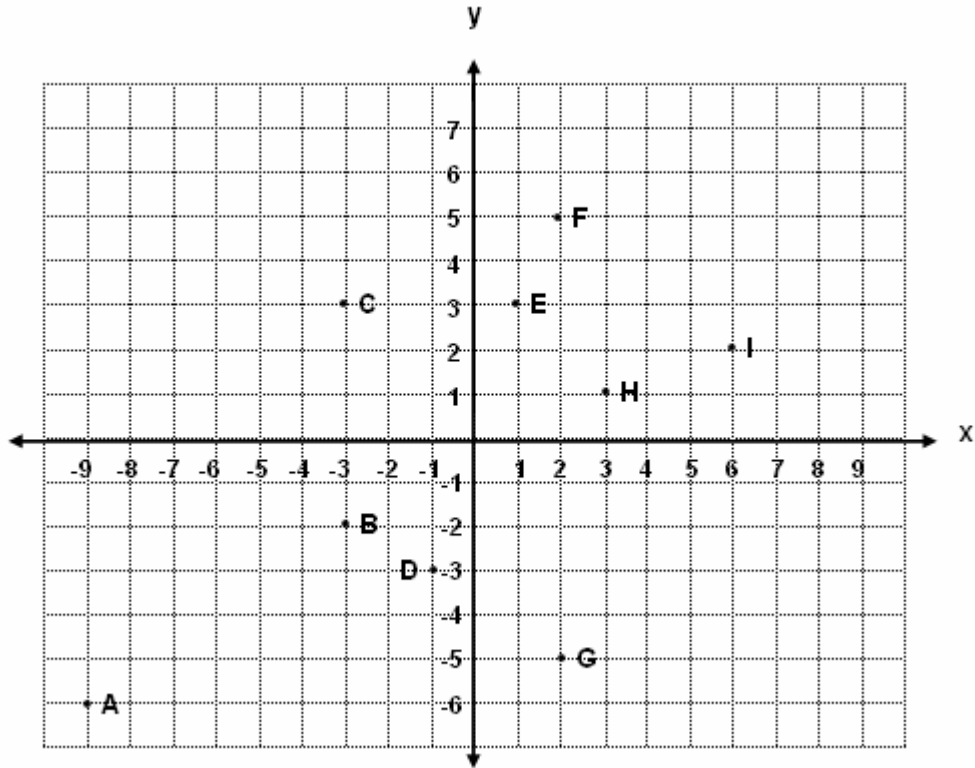

- A. Points D, E, and F
- B. Points D, E, F, and G
- C. Points B, H, and I
- D. Points B, H, I, and G

Go On ▶

Mathematics

8 Study the pattern shown in the table.

What would be the value of s when r equals 10?

r	0	2	4	6	8	
s	7	11	23	43	71	

Show your work.

What is the value of s when r equals 10? _____

Go On ▶

- 9 A company is making shoe boxes from cardboard. The cardboard is 20 inches in length and 16 inches in width. The company is going to cut square pieces off each corner as shown in the diagram below and fold the sides up.

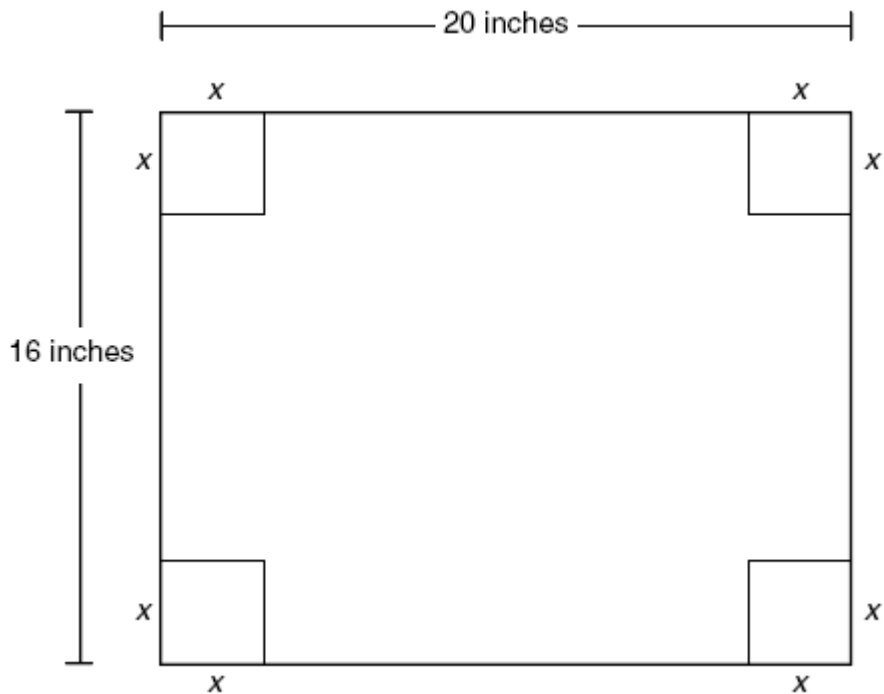

What would be the formula for the **volume** of the box in terms of x ?

- A. $V = 4x^3 - 72x^2 + 320x$
- B. $V = x^3 - 36x^2 + 320x$
- C. $V = 4x^2 - 72x + 320$
- D. $V = 320x$

Go On ▶

Mathematics

- 10 The following table shows the relationship between some Fahrenheit temperatures and their Celsius equivalents.

°Fahrenheit	°Celsius
-13	-25
-4	-20
5	-15
23	-5
32	0
50	10
68	20

Use this information to create a line graph that shows Fahrenheit temperature on one axis and Celsius temperature on the other. Be sure your graph has:

- a title that tells what the graph is about
- appropriate scales for the axes
- accurate labels for the axes

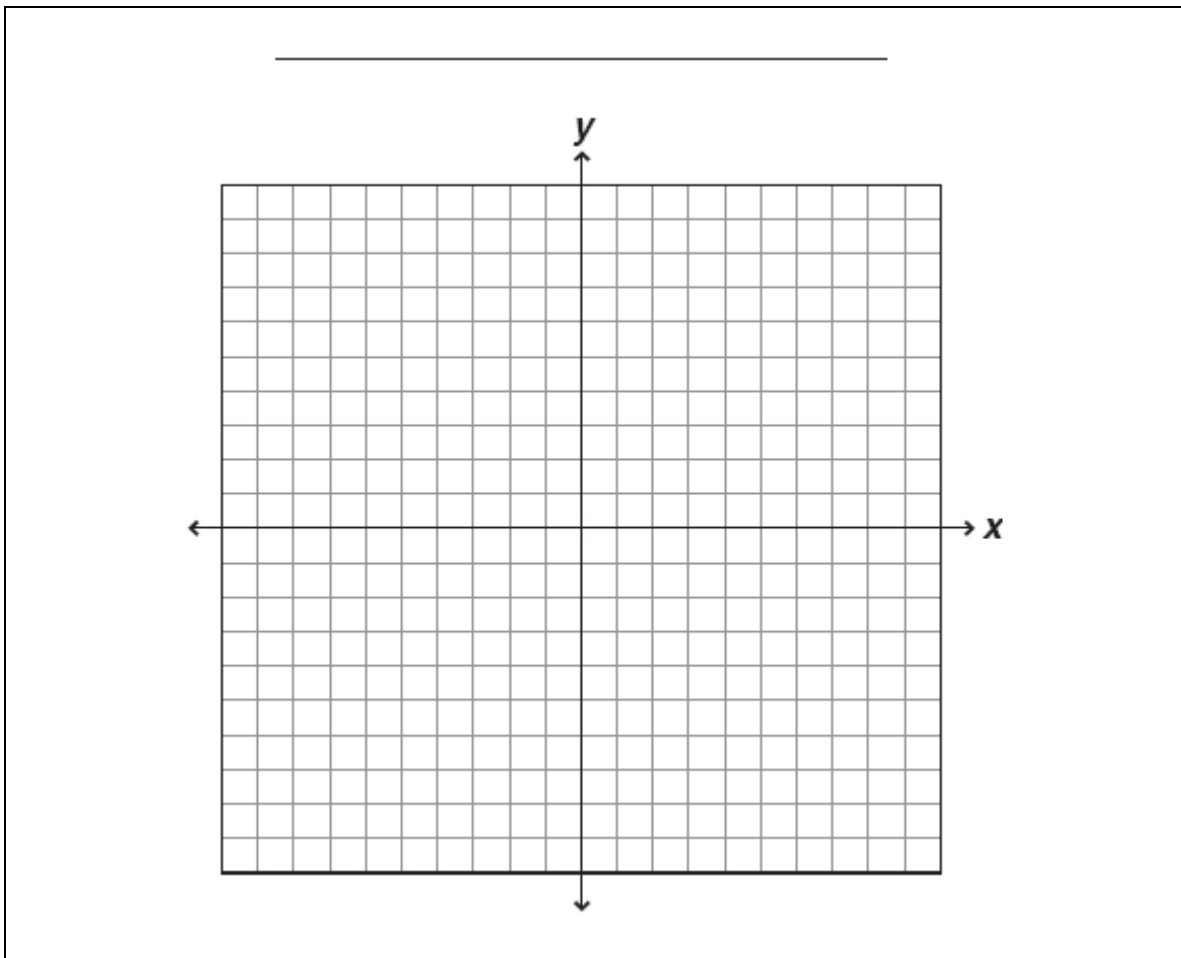

Go On ▶

- 11 Joseph and Cindy made up a game in their mathematics class. To earn points in the game, each player rolls a six-sided cube with numbers 1 through 6 on the sides and then flips a coin. When the coin lands “tails up,” the player gets a total number of points equal to the number at the top of the cube. When the coin lands “heads up,” the player’s points are doubled for that turn.

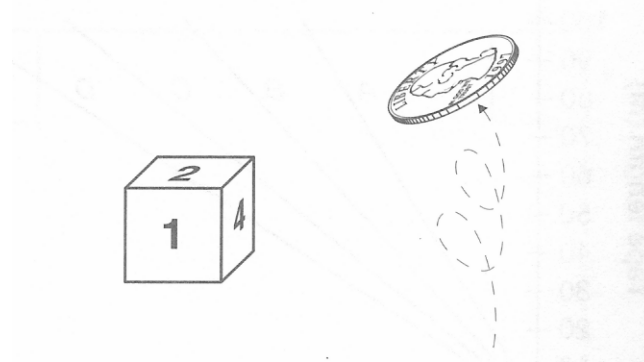

In the box below, list all the possible outcomes for each turn. Then indicate the probability of a player getting 6 points in one turn.

Go On ▶

Mathematics

- 12 Kesha is planning to rent a van for her trip to Mt. Rainier. Two of her friends each rented the same type of van from the same car rental company last week. This is what they told her:

John: "The cost of my rental was \$240. The company charged me a certain amount per day and a certain amount per mile. I had the rental for five days and I drove it 200 miles."

Katie: "The cost of my rental was only \$100. I drove it for 100 miles and had it for two days."

Kesha plans to get the same type of van that John and Katie had from the same car rental company. Kesha estimated her trip would be 250 miles, and she would have the vehicle for four days.

Let C = cost, M = miles, and D = days

Which of the following equations could Kesha use to figure out how much her rental would cost?

- A. $C = 40.00M + 0.20D$
- B. $C = 40.00D + 0.20M$
- C. $C = 20.00M + 0.40D$
- D. $C = 20.00D + 0.40M$

Go On ▶

- 13 Homeowners want to replace some old wooden steps with concrete steps. They make the following drawings and bring them to your construction company. They want an estimate of the total cost.

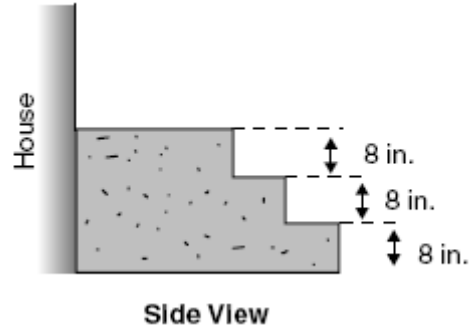
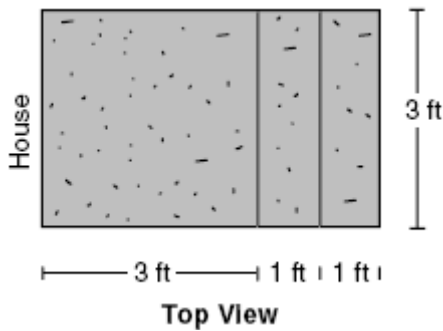

You explain that a wooden form is built for each step, and concrete is then poured into the form. Concrete is delivered in cubic yards. The bottom step is completed first, then the middle, and then the top. You show them the drawing and the price list below.

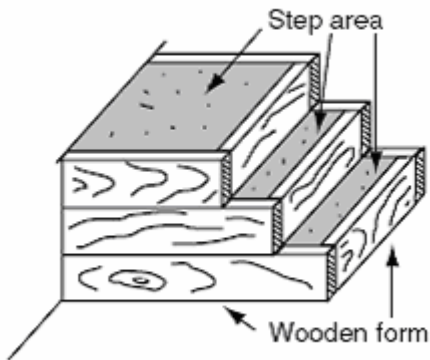

Delivered ready-mixed concrete \$40/cu yd

8 in. wide wooden forms with 1 in. thick boards. \$1.50/ft

Surfacing the concrete. \$0.50/sq ft (putting smooth surface on step areas)

Go On ▶

- 14 The school carnival has a dart game. A dart randomly hit the board.

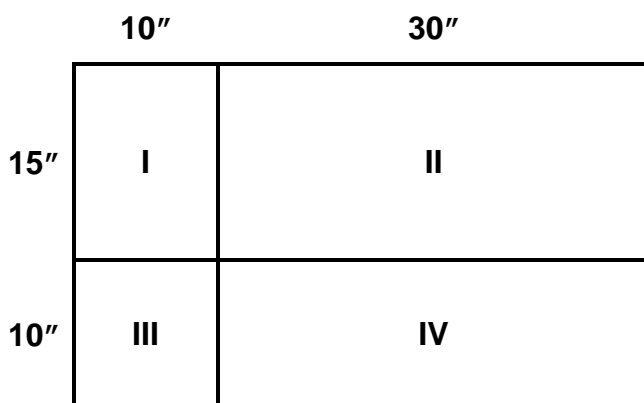

What is the probability that it landed in region II?

- A. $\frac{9}{20}$
- B. $\frac{6}{13}$
- C. $\frac{1}{4}$
- D. $\frac{1}{3}$

Go On ▶

Mathematics

- 15 Each letter in the diagram represents an angle.

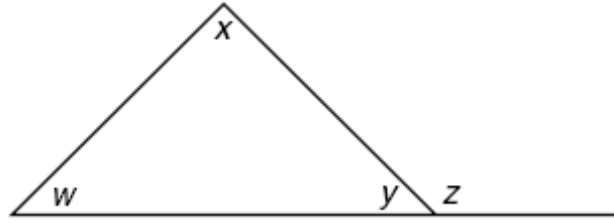

Which of the following statements is true?

- A. $x + z = y + z$
 - B. $w + x > y + z$
 - C. $w + x + y = y + z$
 - D. $w + x + y < y + z$
- 16 Grand Coulee Dam is made of about 10,585,000 cubic yards of concrete.
- Which of the following would give the total amount of concrete in cubic feet?
- A. $10,585,000 \times 27$
 - B. $10,585,000 \div 27$
 - C. $10,585,000 \times 9$
 - D. $10,585,000 \div 9$

Go On ▶

Mathematics

17 Additional work space.

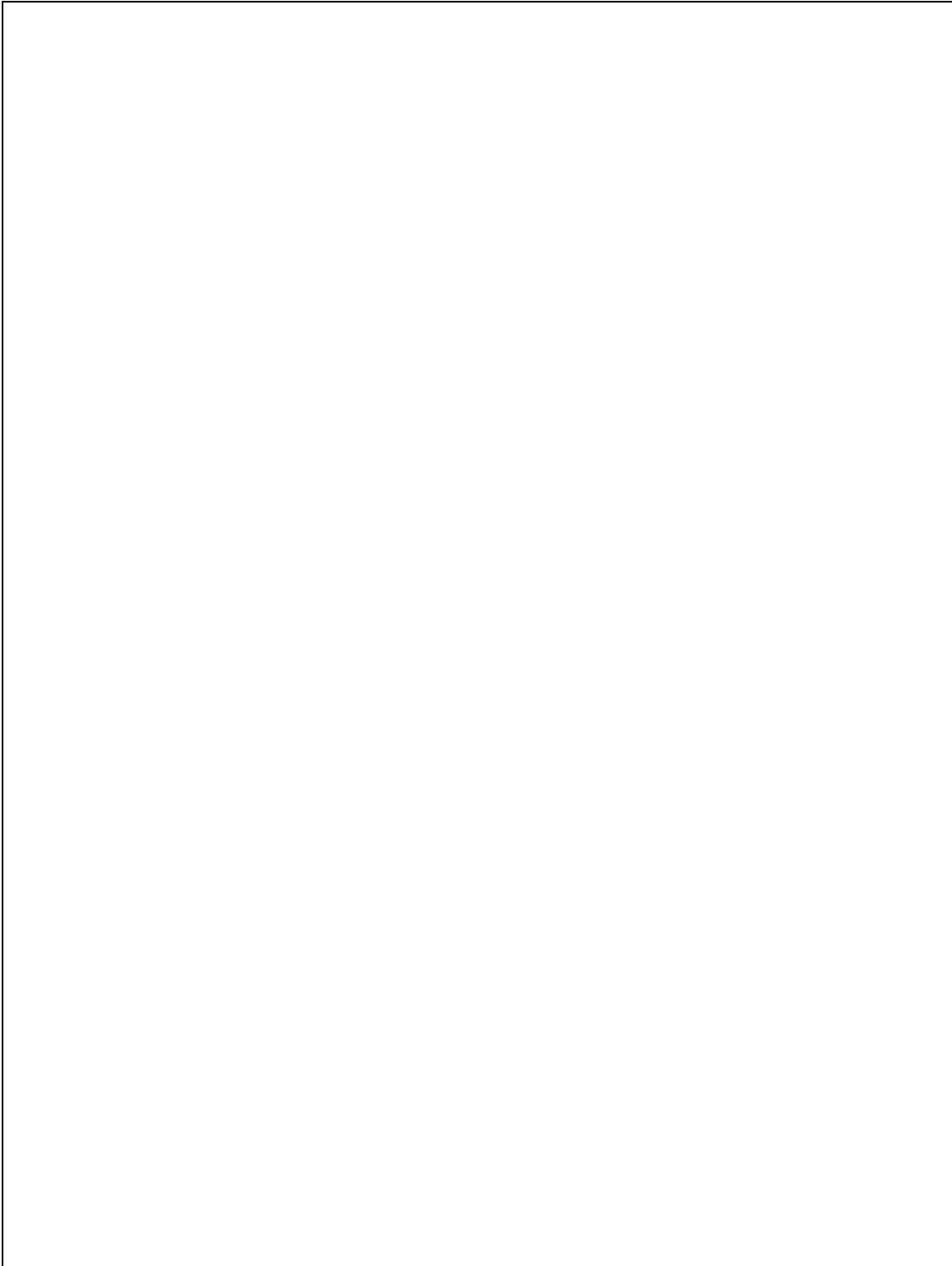

Go On ▶

- 18** The parents' library committee printed 350 books of 24 raffle tickets. After all the tickets are sold, they plan to draw 30 winning tickets. Phil bought 5 tickets. Which of these is closest to the probability that he will win?

- A. $\frac{1}{6}$
- B. $\frac{1}{56}$
- C. $\frac{1}{70}$
- D. $\frac{1}{280}$

Go On ►

Mathematics

19 Look at the graph. The figure will be reflected over the y -axis.

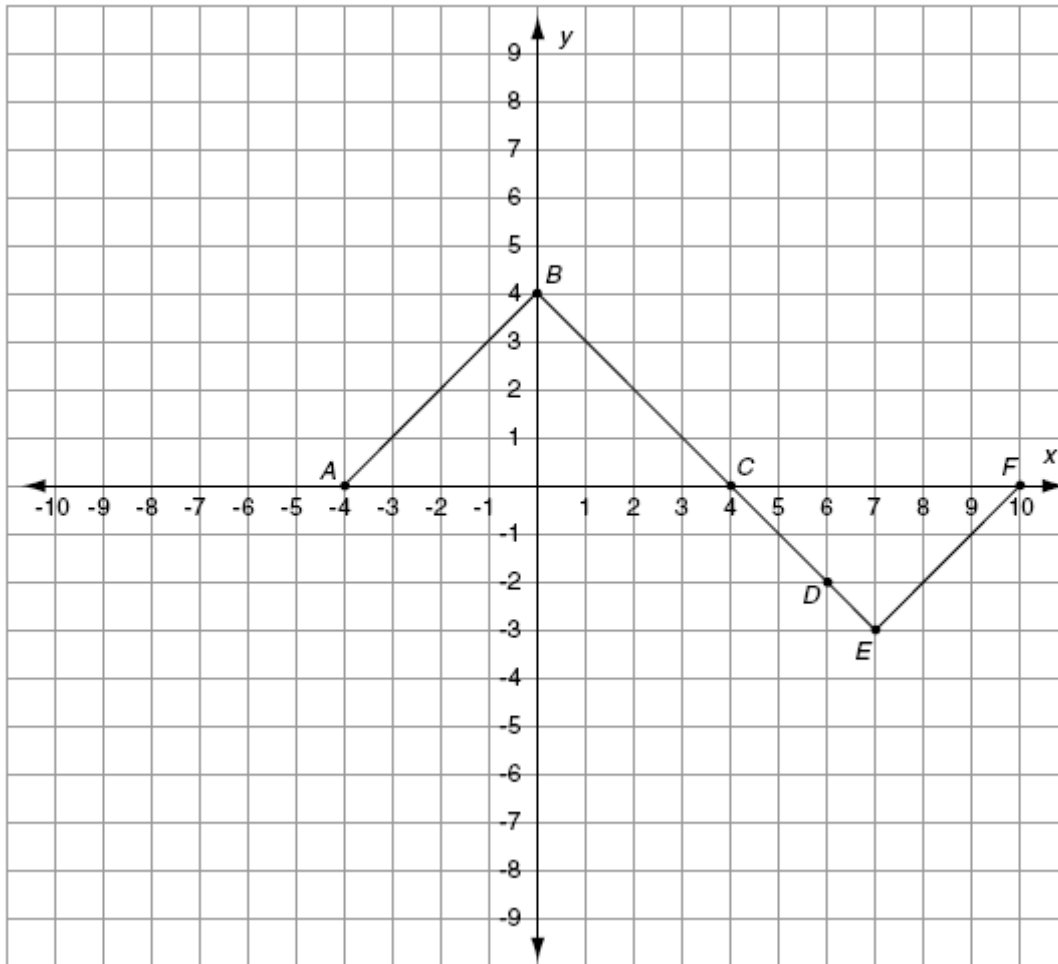

What will be the new coordinates of point D ?

- A. (6, 2)
- B. (-6, -2)
- C. (2, 6)
- D. (-2, -6)

Go On ▶

20 In the isosceles triangle shown, $\overline{AB} = \overline{AC}$.

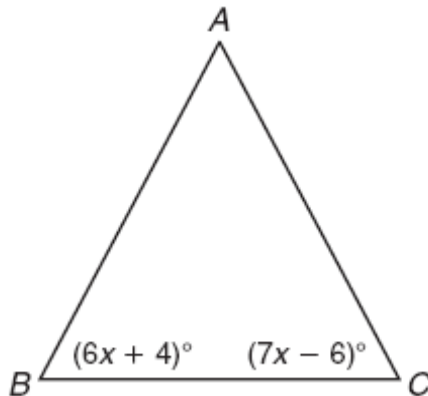

What is the value of x ?

Show your work.

$x = \underline{\hspace{2cm}}$

Go On ▶

Mathematics

- 21** Alice, Bob, Farhana, and Jamal went out for pizza. When the bill came, they decided to split the check. Alice figured out what she owed by multiplying the bill by 0.25. Bob figured his share by finding 30% of the total. Farhana figured out her amount by dividing the total by 3. To determine what he owed, Jamal found 12% of the total.

Who paid the most money?

- A. Alice
- B. Bob
- C. Farhana
- D. Jamal

STOP

25

Directions to the Student: Mathematics

Today you will take Session Two of the Mathematics Assessment. Read each problem and then answer the question. On this part of the test, you are not permitted to use tools such as calculators, rulers, protractors, or other mathematical tools.

Go On ▶

Mathematics

Reminder: Use a No. 2 pencil only. Do not use a mechanical pencil or pen.

22 Terry is designing a flyer to advertise storage boxes that he sells.

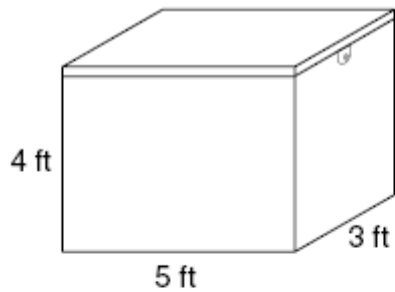

Box A

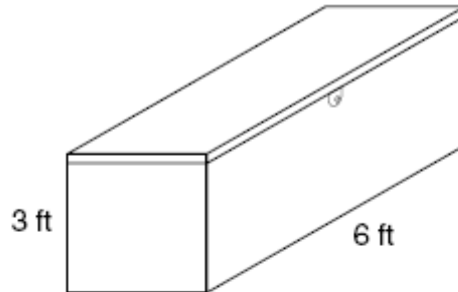

Box C

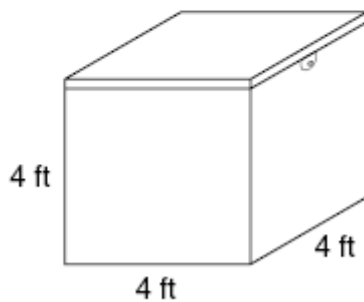

Box B

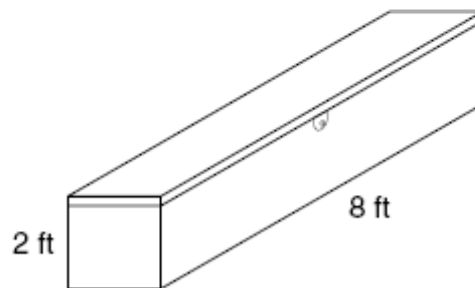

Box D

He wants to show the boxes **from least to greatest** volume. What is the correct order?

- A. B A C D
- B. A B C D
- C. D C B A
- D. D C A B

Go On ▶

23 In parallelogram $PQRS$, the measures of angle P and angle R are each 146° .

What is the measure of angle Q ?

- A. 146°
- B. 112°
- C. 68°
- D. 34°

Go On ►

25 Which term is a factor of $3a^2 + 12a$?

- A. $3a$
- B. $4a$
- C. $3a^2$
- D. $4a^2$

26 Look at the figure on the grid.

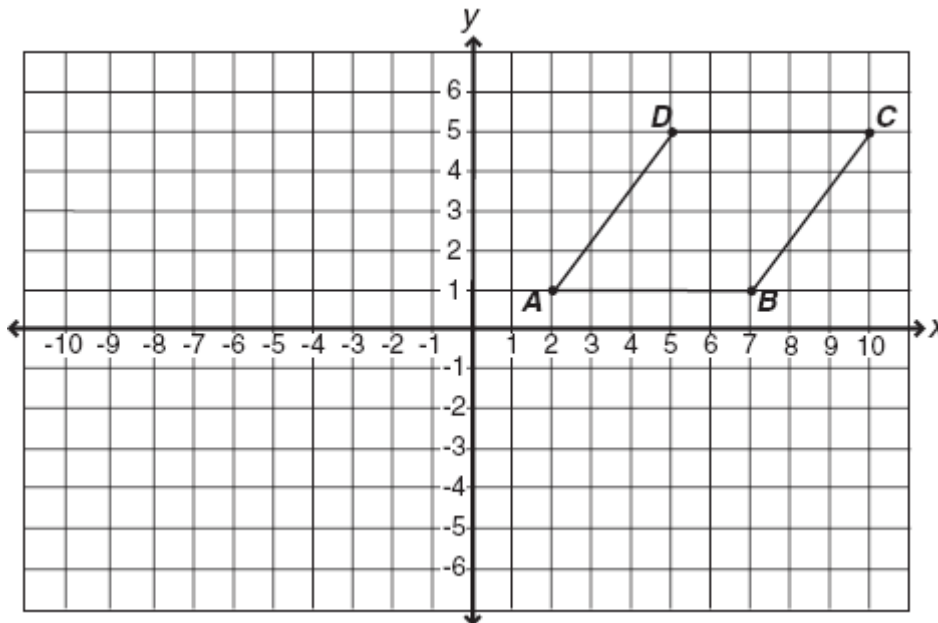

When the figure is translated so that point C is moved to the origin, and point D is moved to the x -axis, what are the new coordinates of point A ?

- A. (9, 6)
- B. (4, 8)
- C. (3, 9)
- D. (8, 4)

Go On ▶

Mathematics

- 27** The Acme Recycling Company has three salary options for its part-time summer employees. The total money earned is related to the amount of cans recycled and an optional hourly wage.

Option 1: 25¢ a can plus \$1.00 an hour

Option 2: 5¢ a can plus \$5.00 an hour

Option 3: 40¢ a can and no hourly wage

Jamal wrote an equation for each salary option to see what he could make per hour.

Option 1: $y = 0.25x + 1.00$

Option 2: $y = 0.05x + 5.00$

Option 3: $y = 0.40x$

Jamal estimates that he can recycle a minimum of 20 cans per hour.

Based on these equations and Jamal's estimate, which option will allow Jamal to make the most money?

Show your work to support your answer using words, numbers, and/or labeled diagrams.

Which option allows Jamal to make the most money? _____

Go On ▶

Mathematics

29 Look at the chart.

Planet	Mass
Mercury	3.30×10^{23} kg
Venus	4.87×10^{24} kg
Earth	5.97×10^{24} kg
Mars	6.42×10^{23} kg

Which planet has the largest mass?

- A. Mercury
- B. Venus
- C. Earth
- D. Mars

30 Kent is using the scale to compare the weight of various solids.

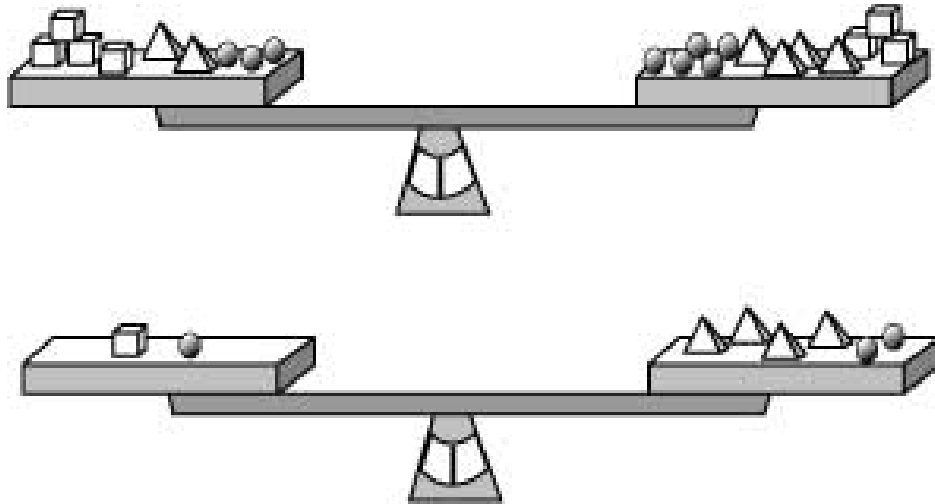

How many spheres will balance one cube?

- A. 2 spheres
- B. 3 spheres
- C. 4 spheres
- D. 5 spheres

Go On ▶

- 31** The diagram shows some of the results of a seven-person contest. When the contest is over, each person will have played one match against every other person. (Not all matches have been played yet.)

An arrow pointing from one player to another means that the first player defeated the second player in their match. For example, player 1 defeated player 3 in their match.

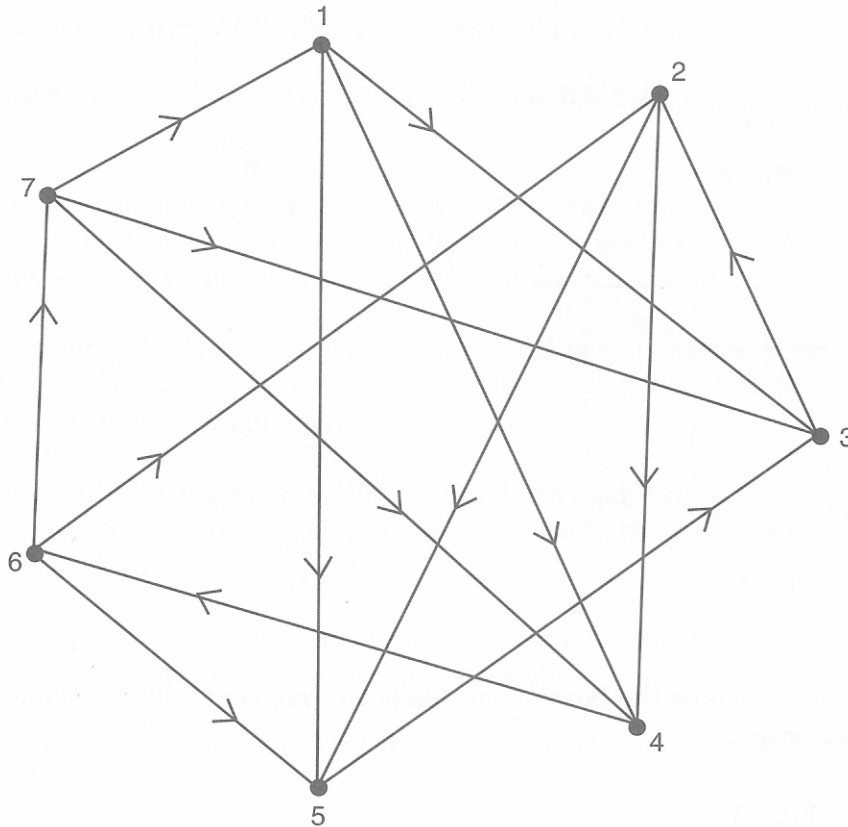

Each player has 2 matches left to play.

Which player has the most difficult matches left to play?

- Organize your results in a way that helps you look for patterns and helps explain your answer. You may want to draw a diagram or make a table.
- Explain the reasons for your answer using information from the diagram.

Go On ▶

- 32 The graph shows the approximate amount of precipitation that fell in Dalton each month during 1996.

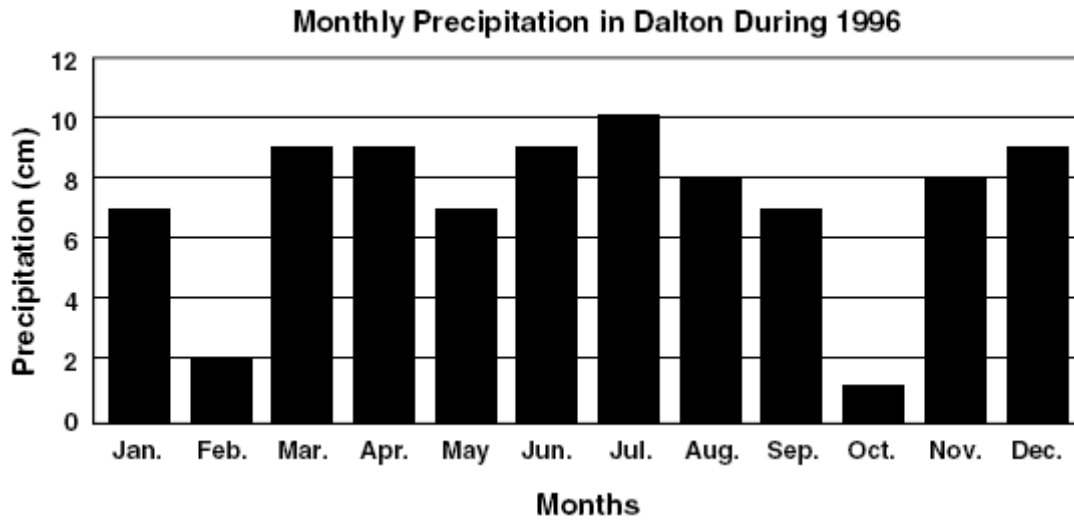

What was the **median** amount of monthly precipitation in Dalton during 1996?

- A. 7 cm
- B. 8 cm
- C. 9 cm
- D. 10 cm

Go On ▶

Mathematics

- 33 The chart shows the amount of total salary (commission plus base salary) paid to employees of a store that specializes in big screen televisions.

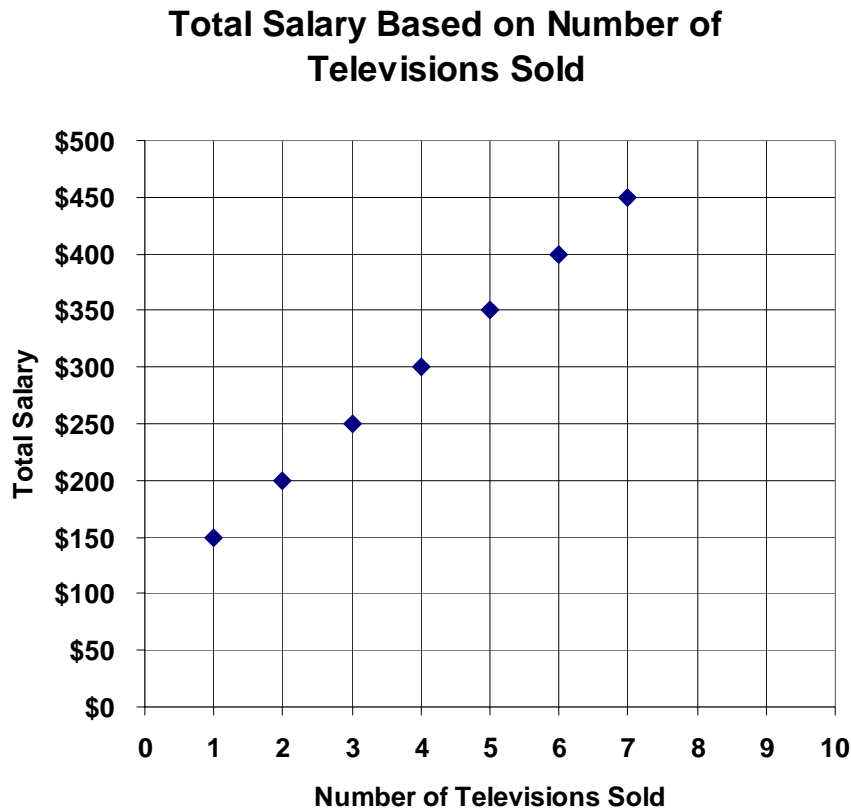

Which equation best represents the total salary (T) that an employee makes for selling any (n) number of television sets?

- A. $T = 50n + 100$
- B. $T = 100(n + 50)$
- C. $T = 100n + 50$
- D. $T = 50(n + 100)$

Go On ▶

- 34 The school playground, a 36 m square, is going to lose part of one corner due to construction. The city will take a triangular section that measures 12 m and 12 m on the perpendicular sides.

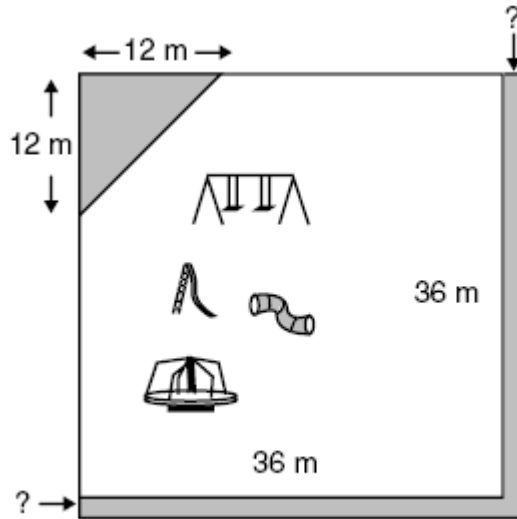

The city has agreed to allow the school to expand the playground on the remaining two sides to replace the lost area.

Find the approximate width of the strip that will be added to each of the two sides.

Show your work.

Approximate width of the strip is _____

Go On ▶

36 When the height of a cylindrical storage tank is 11 m and the radius is 10 m, what would be its volume?

- A. 314 m^3
- B. 691 m^3
- C. $1,100 \text{ m}^3$
- D. $3,454 \text{ m}^3$

37 Luis wants to put carpet in a triangular shaped showroom. He knows the width (W) of the room is 3 feet more than $\frac{1}{3}$ the length (L) of the room. The length of the room is 21 feet.

How many square feet of carpet does he need?

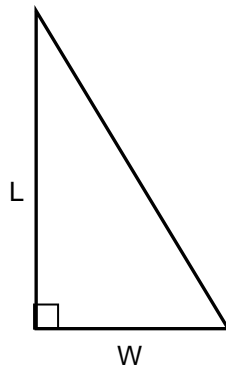

- A. 84 square feet
- B. 105 square feet
- C. 168 square feet
- D. 168 square feet

Go On ▶

Mathematics

38 Suki needs to translate the following bar graph into a circle graph.

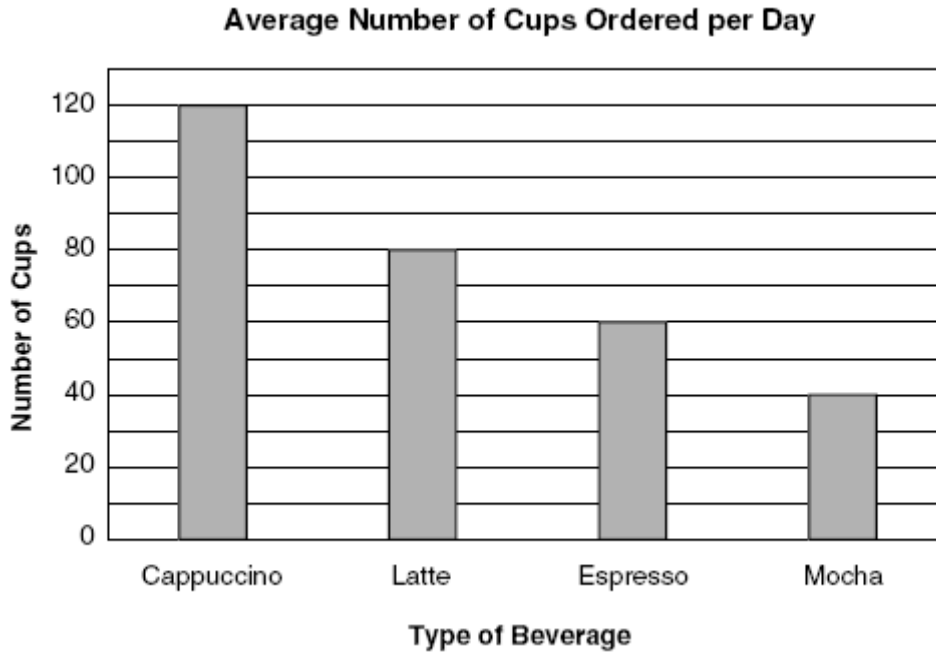

What should be the measure of the angle of the section for espresso?

- A. 20 degrees
- B. 60 degrees
- C. 72 degrees
- D. 90 degrees

- 39 The graph shows information about three groups over a 28-year period—the number of licensed drivers, the number of registered vehicles, and the resident population of a certain area.

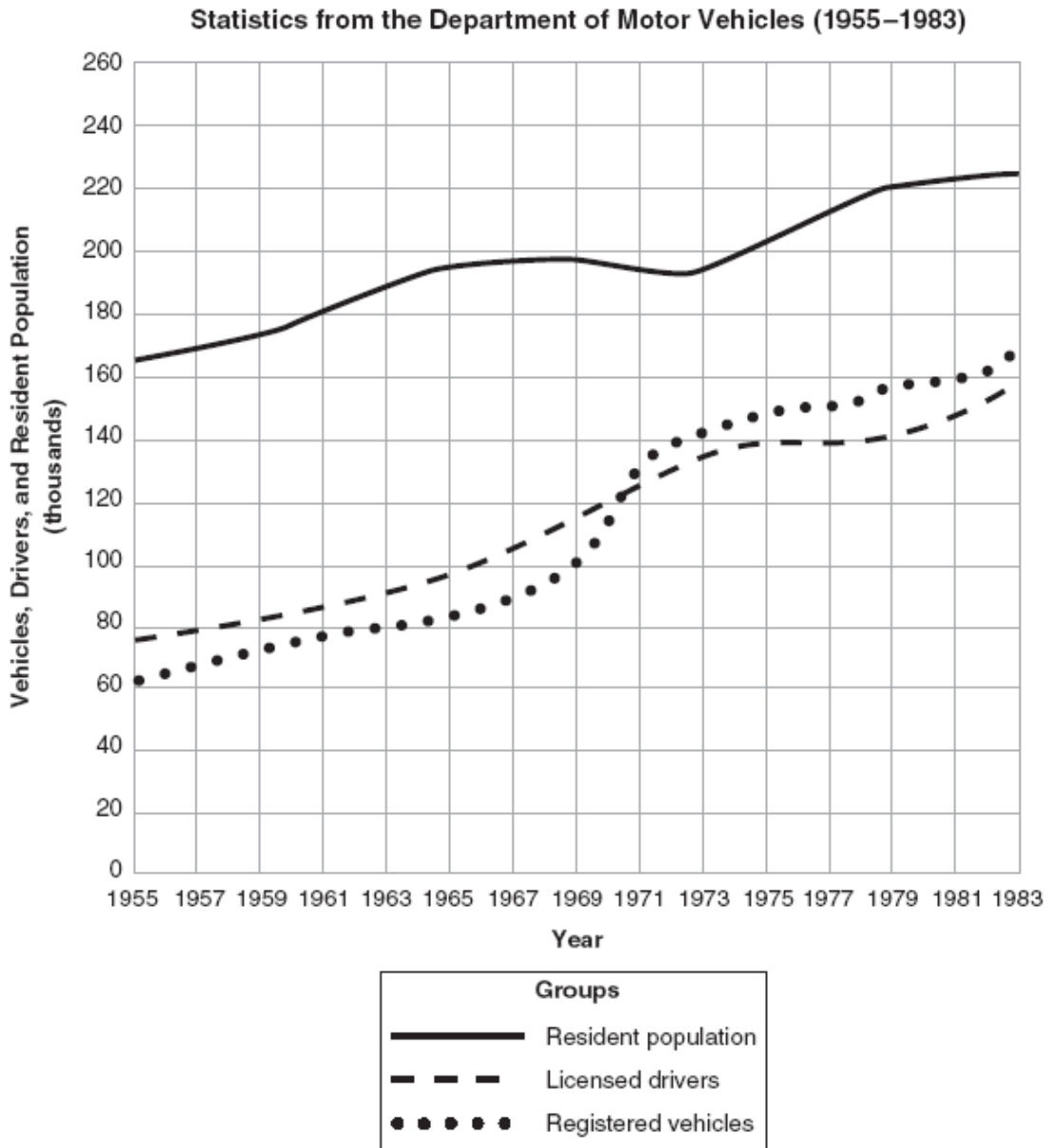

Go On ▶

Mathematics

39 (continued)

Briefly describe the changes that took place for one group during the entire time period shown.

- Name the group.
- Describe the changes using numbers and years in your description.

Describe one way that any two of the groups changed in relation to one another during a particular period of time.

- Name the two groups.
- Give the time period you are considering.
- Describe how the two groups changed in relation to one another during that particular time period.

Go On ▶

Mathematics

- 41** Anita and Ajay play a game of chess. The probability that Anita will win is 48%, and the probability that Ajay will win is 42%. What is the probability that this game will end in a stalemate (tie)?
- A. 6%
 - B. 10%
 - C. 52%
 - D. 58%
-
- 42** Jeremiah is doing an experiment in his mathematics class. He flips four pennies in the air. What is most likely to happen?
- A. Two of the pennies will be heads and two will be tails.
 - B. Three of the pennies will be heads and one will be tails.
 - C. All four pennies will be heads.
 - D. None of the pennies will be heads.

STOP

Name:

Last Name

First Name

MI

Gender:

M F

Grade:

9 10 11 12

Student ID Number: _____

Teacher: _____

School: _____